

# ***Fenco***

***Undercounter Pedestals & Accessories***

***Teller Counter Products***

***Vault & Safe Interiors***



**50 YEARS OF "VALUE BY DESIGN" SINCE 1957**

**FENCO** – Why is **FENCO** the industry leader in teller pedestals and teller counters? Simply put, it's a matter of philosophy. For fifty years **FENCO's** mission statement has not wavered – design and produce the best possible level of quality in a steel teller pedestal and maintain the attitude of accommodating service that every customer deserves.

**FENCO** has not lost sight of its mission. **FENCO** has refused the industry's trend to manufacture cheaper pedestals which still sell at relative costs to the better

pedestals we make today and our competition used to manufacture. At a 5 or 10% selling price difference, yes **FENCO** will lose some orders to competition. But what we will keep is our long-term customer base and our integrity.

We think it's fair to ask you, our customer, what additional value does a product have if the operational life of one is one and a half, two or three times that of another? We believe that value well exceeds a marginal cost differential.

## **FENCO** Teller Pedestal Specifications

All materials and workmanship shall be of the very highest quality as measured by the standards of the industry. All sheet steel shall be of the best grade of mild steel known as Metallic Furniture Stock American open-hearth, free from scale and buckle. Sheets shall be cold rolled and roller leveled, reannealed, pickled and oiled. All gauges specified shall be of U.S. standard.

### PEDESTAL CONSTRUCTION

Pedestal shells shall be an all welded, full height double wall construction, fabricated from 18 gauge steel. All corners are formed, welded and ground flush to effectuate a rigid, seamless, unibody construction. A full depth separating shelf shall be electrowelded in place between each drawer and door compartment to deny entry between same.

### PEDESTAL BASE

The 200 Series pedestal base shall be of all-welded construction fabricated from 16 gauge. It shall provide for a 3" deep x 4" high toespace. Each corner of the base shall have four adjustable levelers to be accessible through the pedestal bottom into the base. The base shall be designed to be removable in the field.

### DRAWERS

All drawers shall consist of the following parts: body, back, outer front, inner front and hardware. The drawer body shall be of 20 gauge steel and shall be formed with two 90 degree bends thus forming the sides and bottom. The outer front fastening shall be by interlocking lips and two metal screws allowing for easy field removal.

### HINGED DOORS

Hinged doors shall be of double-wall construction. The outer door panel shall be of 20 gauge steel end sentinels. All mitered corners are acetylene welded and ground smooth. The inner panel of 20 gauge steel shall cover the lock mechanism and include sound deadening material. Door shall be equipped with institutional hinge, close on a magnetic keeper, and swing right or left. The design shall allow for field swing interchangeability.

### SLIDING DOORS

Sliding doors shall have the same general specifications as hinged doors. Each sliding door shall be equipped with two ball bearing sheaves and roll on sheave track in the lower guide channel.

### FINISHING

**Metal Pretreatment:** Three stage full submersion Iron Phosphate Wash System with Final Rinse containing metal Sealer.

**Pre-Painting treatment:** Before actual painting of components, each and all surfaces of the unit shall be thoroughly wiped with a tack cloth to remove any residual contamination.

**Finish Coat:** The finish coat of all components shall be a dry powder based industrial coating. The final finish shall consist of one or more coats

to establish a dry film thickness of 1.5 mils. The gloss shall be a medium rubbed effect with a 35-45% angular sheen. All components will be oven cured at a temperature of 300 degrees for 15 minutes.

A choice of 16 standard decorator colors is offered on all casework. In addition, **FENCO** shall provide custom color matching as a costed option.

### LOCKS

**FENCO'S** standard drawer and door locks shall be five disc tumbler, interchangeable core, paracentric keylocks. Master keying is standard. Three operating keys shall be supplied to each pedestal. Master keys are available at a nominal charge. The core changeable key is available by request and shall allow for the changing of the core without use of tools or any other means. **FENCO**, as a costed option, offers a high security lock alternative in the form of the Best Lock company's bolt or snaplock interchangeable core lock series. Same can be applied to any **FENCO** drawer or door by specifying same on your purchase order.

### COIN LOCKER DESIGN

**FENCO** offers both a 3" collar design as well as a full locker design. Both shall feature a 1/4" steel body with the option of either a 1/4" door or a 1/2" thick door. The locker door shall provide for three point, live action (up, down and side), boltwork with a full height, hinge side, dead bar. The combination lock shall be a U.L. listed lock with the option to add a keylock (for dual security) to same. The boltwork shall be thrown by a keylocking locker handle which may be keyed to, or different from, the pedestal's drawer locks. The combination lock bolt, when thrown, shall interlock into **FENCO'S** live three point boltwork action to act as a fourth point.

### DRAWER SUSPENSIONS

All drawers shall be provided with a highly perfected, three member progressive, all steel bearing, side arm suspension. The suspension shall consist of three distinct members; outer member, ball retainer with ball bearings and an inner member. Load rating of suspension not to be less than 155 lbs. Manufactured by **Accuride, Inc.** Same shall carry a lifetime warranty.

### DAMAGED/LOST SHIPMENTS

Though title does not pass until merchandise is paid for, customer assumes liability for lost or damaged merchandise shipped by common carrier, and should determine the extent of coverage by the common carrier for loss or damage. Any merchandise delivered damaged by a **FENCO** truck will be covered by **FENCO** directly. In either case, any damage to merchandise or to carton must be noted at time merchandise is received.

### RETURNS

Returned merchandise will not be accepted without prior consent. A restocking charge of forty percent (40%) will be charged on all painted products and twenty-five percent (25%) on all hardware or unpainted products as long as those products are received back in good condition by **FENCO**. Custom products cannot be returned.



VALUE BY DESIGN SINCE 1957

## FENCO'S VAULT AND SAFE INTERIORS - KEEPING YOU COMPETITIVE

FENCO HAS BEEN PRODUCING VAULT AND SAFE INTERIOR (VSI) UNITS FOR CASH TRAY, COIN, BULK & LOOSE CASH STORAGE, AND MISCELLANEOUS ITEMS STORAGE SINCE 2007. OUR 18 GAUGE, DOUBLE-WALL, ALL WELDED BODY CONSTRUCTION WITH 1/8" STEEL PLATE LOCKING DOORS OFFERS A LIGHTER GAUGE, LOWER COST SOLUTION FOR TODAY'S MARKETPLACE. WE OFFER OUR VSI UNITS IN VARIOUS MODELS, CONFIGURATIONS AND SIZES WHICH CAN BE EASILY STACKED TOGETHER TO CREATE AN ENDLESS AMOUNT OF CONFIGURATIONS TO SUIT JUST ABOUT ANY INTERIOR LAYOUT DESIRED.

OUR VSI UNITS ARE OFFERED IN ALL OF OUR STANDARD COLOR FINISHES & LOCKING OPTIONS COMPLIMENTED BY VARIOUS MODIFICATIONS & ACCESSORIES (LOOSE CASH FILING ROLL-OUT TRAYS, CUSTOM HEIGHT BASES & REMOVABLE CASH DRAWER / RCD STORAGE LOCKER CONVERSIONS). PLEASE VISIT OUR WEBSITE OR GOLDLINE BROCHURE TO VIEW ALL AVAILABLE MODELS.

### SAMPLE MODELS AND FINISHES BELOW



### CONTACT US:



WWW.FENCOBANKEQUIPMENT.COM ♦ 800-486-8484 X 102 ♦ MATTJR@UHFENCO.COM  
4422 RT. 130 / PO BOX 1238, BURLINGTON, NJ 08016

## FENCO #200 Series Teller Pedestals

**FENCO's** #200 Series stand-up (38½" h) pedestal line offers the versatility you require to design your teller line, back counter and work room. The four different pedestal widths in a variety of drawer/door configurations allow you to maximize the efficiency in your space planning. **FENCO** offers 16 standard colors to accommodate even the most adventurous interior designers. Custom colors are also available at a nominal upcharge. The pedestals shown below with locks, feature **FENCO's** standard interchangeable

core deadbolt lock. As noted in our specifications listing, you may upgrade, as a costed option, to either a Best Lock™ interchangeable core dead bolt or snaplock.

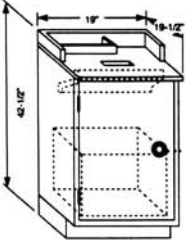
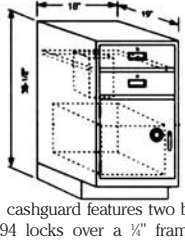
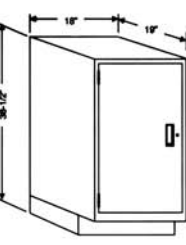
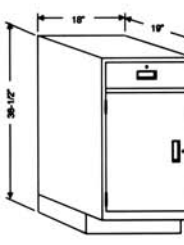
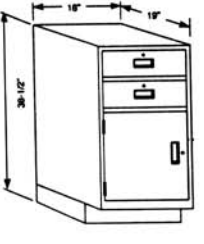
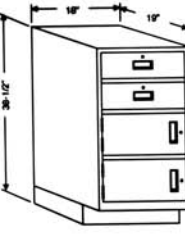
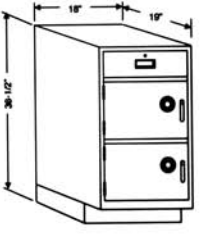
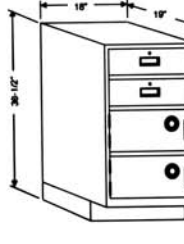
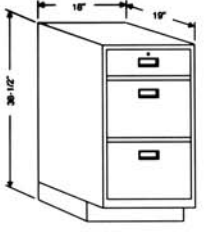
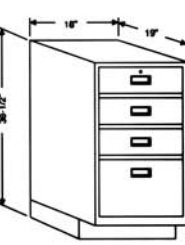
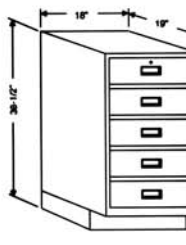
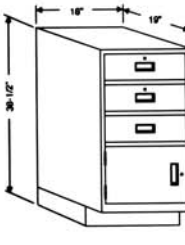
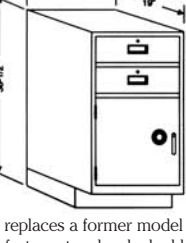
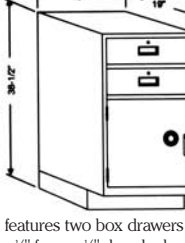
**FENCO's** pedestals are manufactured to ship in about a month, but they're manufactured to last more than a decade. That's an equation in time of which we're quite proud. So the next time you're in need of undercounter, call **FENCO**, where the value is by design. It's only a matter of time.

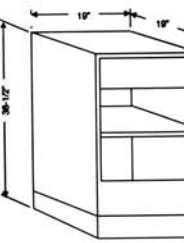
 <p>Model 200 Lobby Depository features a double pan door with combination lock and a removable envelope bin. Weight: 150 lbs.</p>	 <p>Model 201 cashguard features two box drawers with No. 94 locks over a ¼" frame, ½" door locker. The unit features a cash drop system from top drawer to locker. A pullout drop bin is included. Weight: 204 lbs.</p>	 <p>Model 202 features a double pan cupboard door with No. 94 lock and two adjustable shelves. Weight: 105 lbs.</p>	 <p>Model 203 features one box drawer over a double pan cupboard door with No. 94 lock and one adjustable shelf. Weight: 117 lbs.</p>
 <p>Model 204 features two box drawers over a double pan cupboard door with No. 94 lock and one adjustable shelf. Weight: 127 lbs.</p>	 <p>Model 205 features two box drawers over two double pan cupboard doors with No. 94 lock. Weight: 138 lbs.</p>	 <p>Model 206 features one box drawer over two ¼" frame, ½" door lockers. Each locker is equipped with 3 point boltwork and group 2 combination locks. Weight: 206 lbs.</p>	 <p>Model 207 features two box drawers over two ¼" frame, ½" door lockers. Each locker is equipped with group 2 combination locks. Weight: 219 lbs.</p>
 <p>Model 210 features one box drawer with No. 94 locks over two legal drawers w/HS. Weight: 140 lbs.</p>	 <p>Model 212 features three box drawers (top one locked) over one legal drawer w/HS. Weight: 156 lbs.</p>	 <p>Model 214 features five box drawers. The top drawer is equipped with a No. 94 lock. Weight: 173 lbs.</p>	 <p>Model 216 features three box drawers (top two with No. 94 lock) over a double pan cupboard door with No. 94 lock and one adjustable shelf.</p>
 <p>Model 220 replaces a former model offered 221. Model 220 features two key locked box drawers over a full ¾" locker with a ¼" door. The locker is equipped with 3 point boltwork, a group 2 combination lock and one adjustable shelf.</p>	 <p>Model 222 features two box drawers with No. 94 locks over a ¼" frame, ½" door locker. The locker is equipped with 3 point boltwork, a group 2 combination lock and one adjustable shelf. Weight: 195 lbs.</p>	 <p>Model 225 features three box drawers (top two with No. 94 lock) over a ¼" frame, ½" door locker. The locker is equipped with 3 point boltwork and a group 2 combination lock. Weight: 189 lbs.</p>	 <p>Model 226 is a corner pedestal designed for use in a return station application. Weight: 96 lbs.</p>

## Fenco #200/#600 Series Teller Pedestals

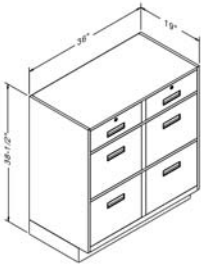

Model 211 features two box drawers over four legal drawers w/HS.  
Weight: 238 lbs.

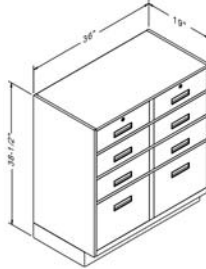

Model 213 features six box drawers over two legal drawers w/HS.  
Weight: 262 lbs.

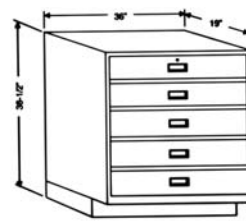

Model 229 features five full width drawers. The top drawer is equipped with a No. 94 lock. As a costed option, full width inserts and/or a ganglock is available.  
Weight: 291 lbs.

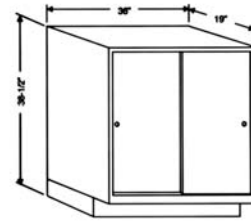

Model 231 features two double pan sliding doors and two adjustable shelves.  
Weight: 160 lbs.

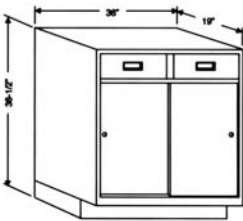

Model 241 features two box drawers over two double pan sliding doors. The pedestal includes one adjustable shelf.  
Weight: 177 lbs.

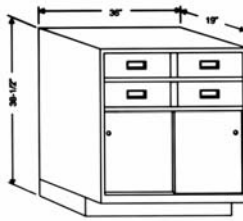

Model 251 features four box drawers over two double pan sliding doors. The unit includes one adjustable shelf.  
Weight: 207 lbs.

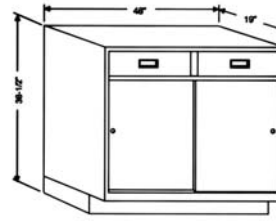

Model 267 is a 48" wide pedestal with two box drawers over two double pan sliding doors. The unit includes one adjustable shelf.  
Weight: 199 lbs.

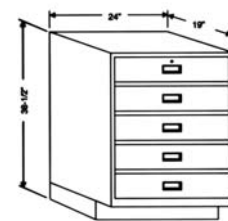

Model 268 features five box drawers. The top drawer is equipped with a No. 94 lock.  
Weight: 196 lbs.

### Fenco #600 Series Teller Pedestals

Fenco's #600 Series low-boy (27 7/8" h) pedestal line is manufactured to the exact standard of Fenco's #200 Series. The #600 Series 27 7/8" overall height meets the A.D.A. requirements as set forth by the Federal Government. Designed in three different widths in a variety of drawer/door configurations, the #600 Series pedestal line can also be used as both service desk pedestals or as sit-down pedestals in your operations room. As a costed option, the #600 Series pedestal line is capable of accepting pedestal bases in any height required to meet your design layout. Just let us know what height you're most comfortable with and we'll design and produce it for you.

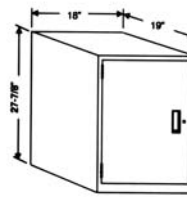

Model 602 is a sit-down height pedestal with a double pan door with No. 94 lock. The unit includes one adjustable shelf.  
Weight: 92 lbs.

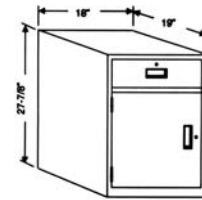

Model 603 is a sit-down height pedestal featuring one box drawer with No. 94 lock over a double pan door with No. 94 lock. The unit includes one adjustable shelf.  
Weight: 107 lbs.

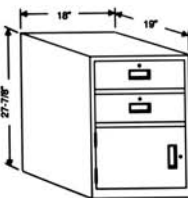

Model 604 is a sit-down height pedestal featuring two box drawers with No. 94 lock over one double pan door with No. 94 lock. The unit includes one adjustable shelf.  
Weight: 122 lbs.

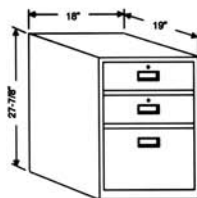

Model 606 is a sit-down height pedestal featuring two box drawers with No. 94 lock over one legal drawer w/HS.  
Weight: 134 lbs.

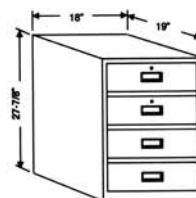

Model 608 is a sit-down height pedestal featuring four box drawers. The unit's top two drawers include a No. 94 lock.  
Weight: 158 lbs.

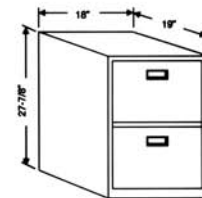

Model 609 is a sit-down height pedestal featuring two legal drawers w/HS.  
Weight: 124 lbs.

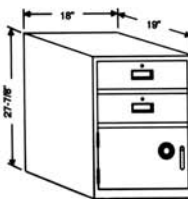

Model 620 is a sit-down height pedestal featuring two box drawers with No. 94 lock over a full 1/2" locker with a 1/4" door locker. The locker is equipped with 3 point boltwork, a group 2 combination lock and one adjustable shelf.  
Weight: 170 lbs.

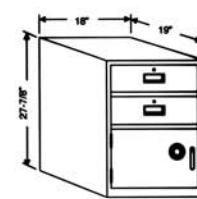

Model 622 is a sit-down height pedestal featuring two box drawers with No. 94 lock over a 1/4" frame, 1/2" door locker. The locker is equipped with 3 point boltwork, a group 2 combination lock and one adjustable shelf.  
Weight: 181 lbs.

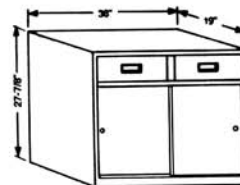

Model 641 is a sit-down height pedestal featuring two box drawers over two double pan sliding doors. The unit includes one adjustable shelf.  
Weight: 161 lbs.

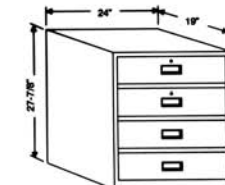

Model 643 is a 24" wide sit-down height pedestal with four box drawers. The top two box drawers come equipped with No. 94 locks.  
Weight: 159 lbs.

## Fenco Teller Line Accessories

From box drawer units to waste baskets . . . from drop-in card inserts to cash trays . . . from adjustable kneespace shelving to adjustable follower blocks, **Fenco** accessories integrate well into your new or existing system. Many different cash/coin trays constructed of steel or ultra-plastic, four different-sized note inserts, and a large assortment of options allow you to create the system that is right for you!

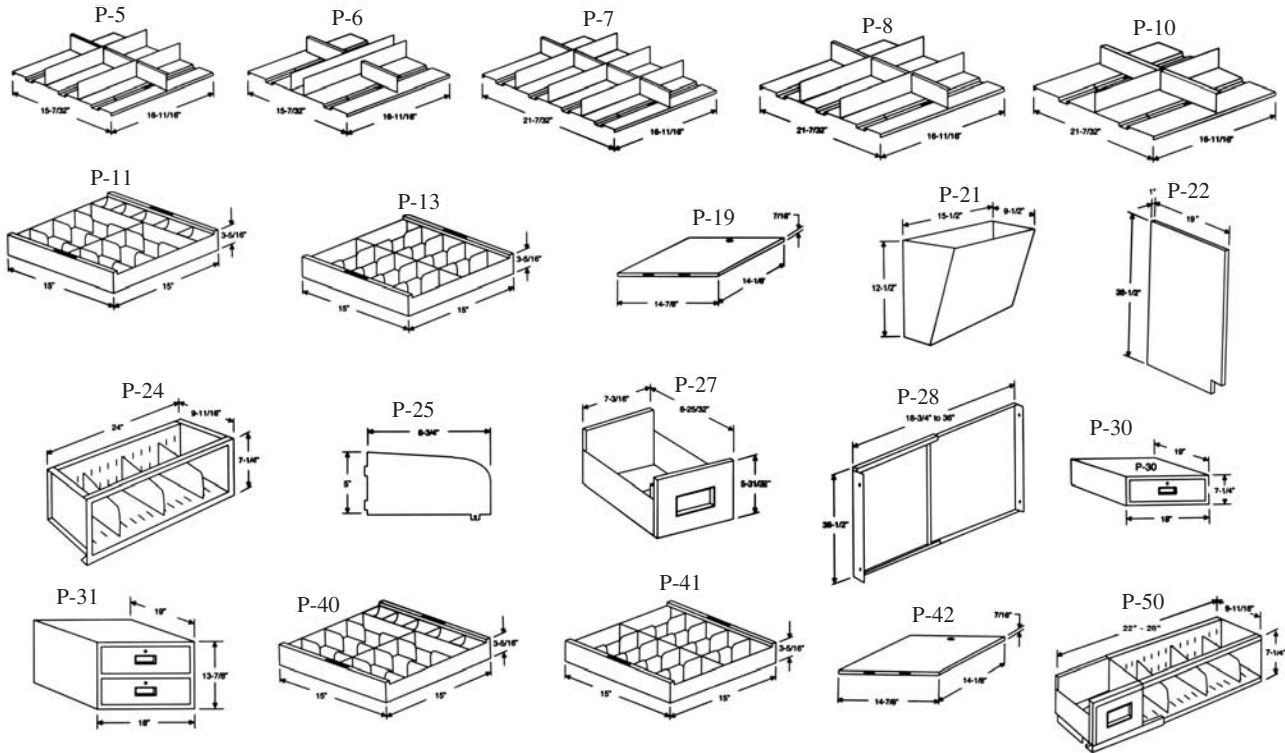

### Fenco is introducing...

...new accessory products as shown below. Model P-15 is a metal note sorter tray, handy for filing any size note or slip up to 4"H x 9-3/4"W. This tray may sit on a desktop or in our pedestal's box drawers, offering a cross-filing application.

Model P-17 is a new cash tray offering five cash compartments, six compartment coin scoops & rear tray area for note, or bulk storage.

Model P-52 is a low height, 5-1/2"H, adjustable width kneespace assembly. The low height offers more undercounter kneespace height when required.

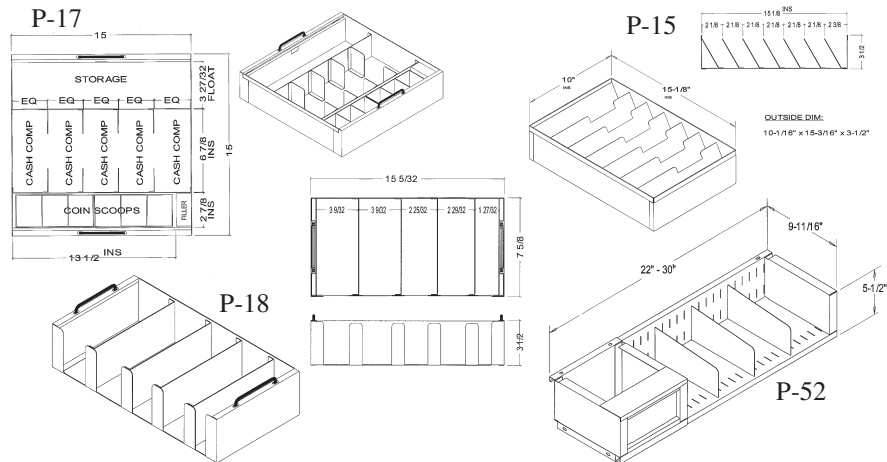

## Fenco Interchangeable Unit Teller Stations

Everyone manufactures prefab teller stations, but only **Fenco** offers you the flexibility of interchangeable pedestal prefab teller stations with no modification charges assessed. Need a coin locker pedestal in place of a doublepan cupboard pedestal? No problem. Would you prefer a single-width return pedestal in place of a double-width return pedestal? Whatever your design needs call for, it's workable with this design. For costing, simply deduct the cost of the model you're deleting and add the cost of the replacement model. Creativity by **Fenco**, satisfaction by customer.

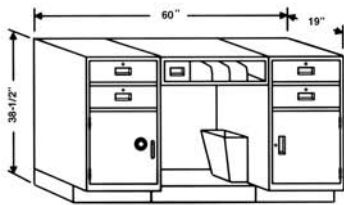

#1000 interchange unit prefab 60" wide, 38½" high, teller station shown here consisting of one #222L19, one #204R19, one #P-24, one #P-27, one #P-28, one #P-13, one #P-19, and one #P-21.

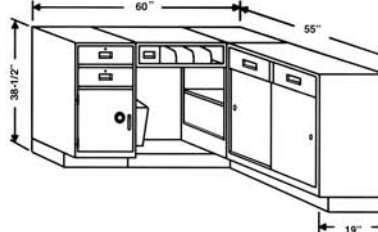

#1010 interchange unit prefab 60" wide, 38½" high, teller station shown here consisting of one #222L19, one #226X19, one #241X18, one #P-24, one #P-27, one #P-28, one #P-21, one #P-13, and one #P-19.

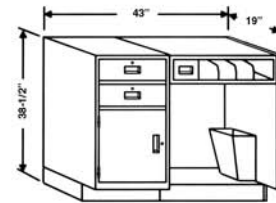

#1040 interchange unit prefab 43" wide, 38½" high, teller station shown here consisting of one #204L19, one #P-24, one #P-27, one #P-28, one #P-22, one #P-21, one #P-13, and one #P-19.

## FENCO New Removable Cash Drawer and Storage Systems

FENCO has redesigned its removable cash drawer and storage system to match the dimensional layout and design utilized most often in the industry today. FENCO's new RCD model P-111 will now be interchangeable with both the Hamilton Safe and Korden pedestal & storage units. In addition, FENCO now offers two new storage units, models BUS-108 & BUS-116, to existing models, Bus-106 & Bus-112. Each of the storage units may be purchased without the castor design shown for stationary storage.

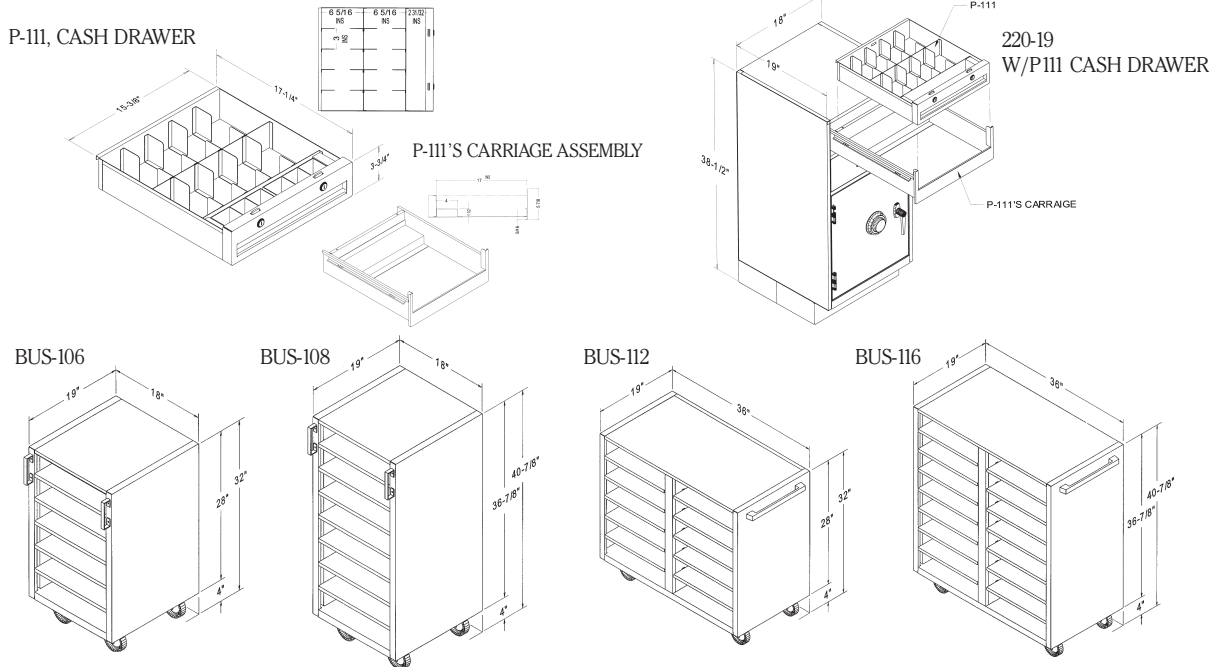

## FENCO C.P.U. Pedestal Conversion

We at FENCO continually look for better ways to design our pedestals to meet the industry's changing needs. We have had many requests from customers to incorporate the storage of CPU's with our undercounter steel. We have designed a number of new models, which can satisfy the needs of a teller's daily functions as well as house a CPU. Originally we had only one cabinet designed for the CPU, our CTP-2000. We are now adding several more, which can be seen below: **204-19-CPU, 205-19-CPU, 226-19-CPU & 216-19-CPU.**

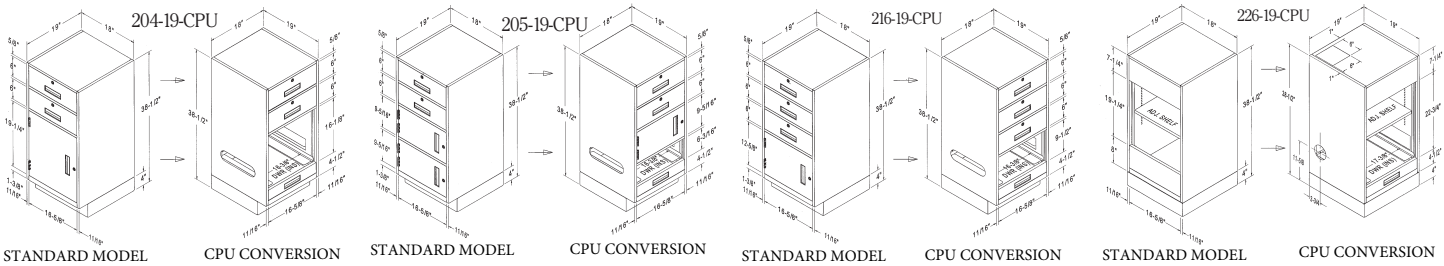

## Bus Conversion

FENCO now offers you the ability to convert any stationary pedestal to a Bus Model with its unique factory installed Bus Conversion assembly. You can now convert any 18", 24", 36" or 48" wide pedestal to a Bus unit. This factory installed assembly creates the widest variety of teller buses available by adding it to any fixed base Model FENCO offers. That is flexibility no other manufacturer offers and the availability you need.

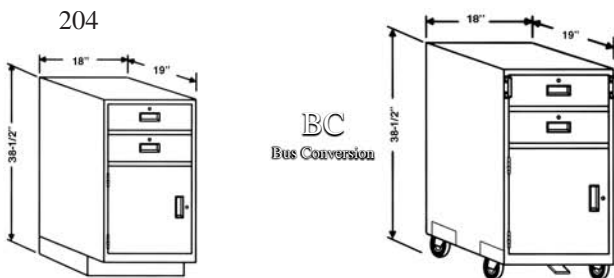

## Teller Vault/Note Buses

In addition to FENCO'S Bus Conversion assembly, FENCO also offers you a choice of two teller vault buses, Models #412 and #585. Both are designed to accept any FENCO cash tray as well as our competition's. Model #587 is a teller note bus designed to accommodate commercial sized notes and checks up to 5 1/4" h x 10 1/2" w.

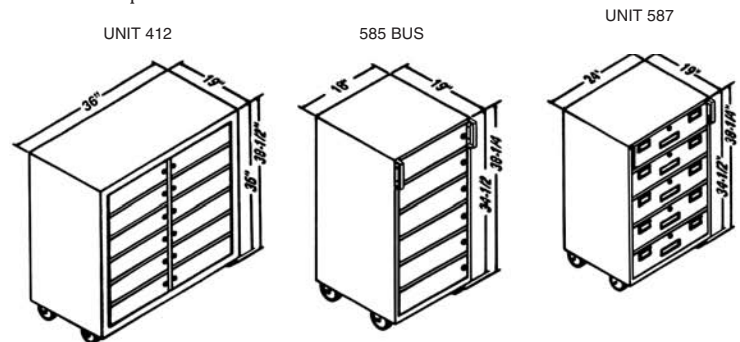

## Lateral Files

New from **FENCO** is its non-insulated lateral file line. We designed the line with the same rugged security grade specifications as **FENCO'S** undercounter line, yet its look will compliment today's fashionably designed office layout. The line features a safety interlocking system, ganglocking system and full extension drawers on Accuride™ suspensions. **FENCO'S** full line color finishes are available to complement your undercounter installation.

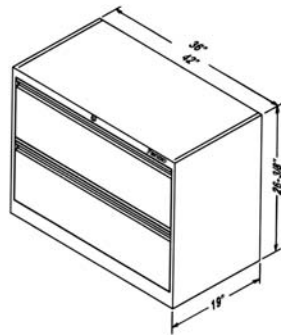

1202-36 (2) DRAWER UNIT 36" WIDE  
1202-42 (2) DRAWER UNIT 42" WIDE

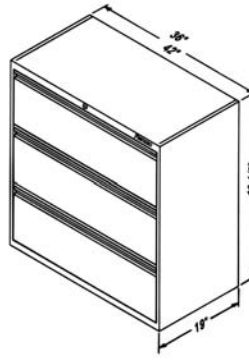

1203-36 (4) DRAWER UNIT 36" WIDE  
1203-42 (4) DRAWER UNIT 42" WIDE

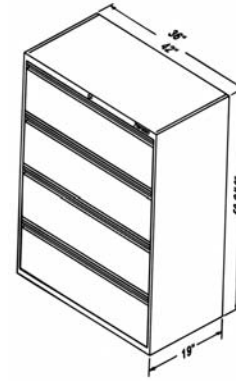

1204-36 (4) DRAWER UNIT 36" WIDE  
1204-42 (4) DRAWER UNIT 42" WIDE

## Fenco Vault and Safe Interiors

With encouragement and input from our national dealer base, **FENCO** has introduced a new product line, Vault & Safe Interiors. We have designed a variety of models to satisfy your many needs. All models are offered in both a 17" & 24" depth, all of which are available with a variety of lock options.





Our Vault & Safe Interiors are designed to compete against Diebold's double wall construction product line. Previously your options were limited to present either a hard-iron solution (too expensive, too long to get) or a soft-metal solution (which is too difficult to work with dimensionally & configuration-wise). We now have your solution to Vault & Safe Interiors.

### Features

- **Teller Design** – Design the layout that suits your needs best.
- **Integrated, Unibody Doublewall Construction** – Unit welded 18 gauge sheet metal construction; corners welded & ground flush; no overlapping metal seams
- **Multiple Locking Options** – Keylocks, mechanical combination locks & (2) electronic combination locks (LaGard 33E, S&G #6123) available on any door.
- **Solid Plate Doors** – .125" thickness; hot rolled, pickled and oiled.
- **Color Finish** – All 16 **FENCO** color finishes are available; custom finishes available as a costed option.
- **Easy Unit Fastening** – All units feature fastening knockout in unit top and fastening cage nuts aligned in bottom.
- **Safe Deposit Box Dimensions** – **FENCO'S** vault & safe interior unit dimensions in width and depth.
- **Cash Drawer Insert** – (2) rows for loose bills compartment with follow block) is available to be installed in any locker.

### Information Notes

- You may stack & fasten units up to 3 high. It is recommended to design your layout with the largest unit on the bottom & to always fasten all units to each other.
- If you're designing a vault utilizing **FENCO'S** safe & vault units in conjunction with safe deposit boxes, **do not stack safe deposit boxes on top of FENCO'S** safe & vault units.
- **FENCO'S** adjustable shelf carries a static capacity of 75 lbs. evenly distributed.
- Left hand swing is standard on single width units; right hand swings are also available.
- Although **FENCO'S** vault & safe units casings are designed to a 17" or 24" deep specification, **you must add to the casing depth the required lock depth.**

LOCKS OPTIONS	
	# 94R LOCK
	MECHANICAL COMBO LOCK
	# 33E ELECTRONIC LOCK
	S&G 6123 ELECTRONIC LOCK

ADD 1/8" FOR #94R, 1-7/16" FOR MECHANICAL COMBO, 3/4" FOR #33E LA GARD AND 1-7/16" FOR S&G #6123 LOCK TO DEPTH OF UNIT

# Fenco Security Cash Lockers

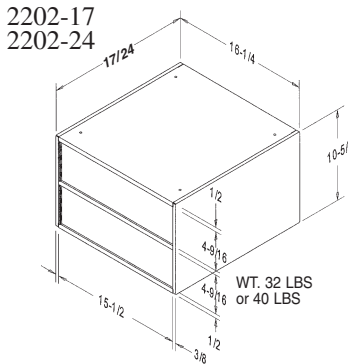

SINGLE WIDTH, (2) TELLER LOCKERS,  
16-1/4" W x 10-5/8" H x 17" D or 24" D

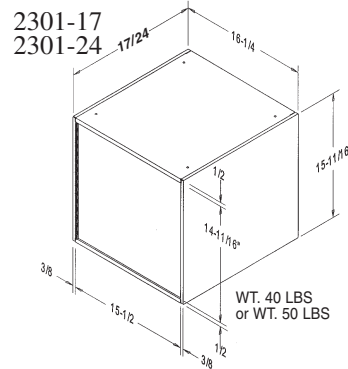

SINGLE WIDTH, (1) MANAGER/CASH LOCKERS  
16-1/4" W x 15-11/16" H x 17" D or 24" D

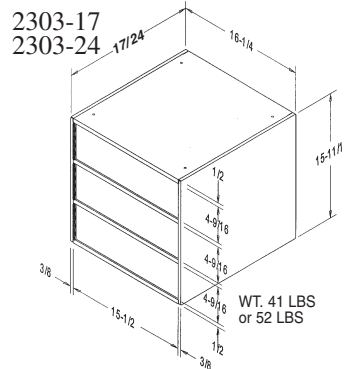

SINGLE WIDTH, (3) TELLER LOCKERS  
16-1/4" W x 15-11/16" H, 17" D or 24" D

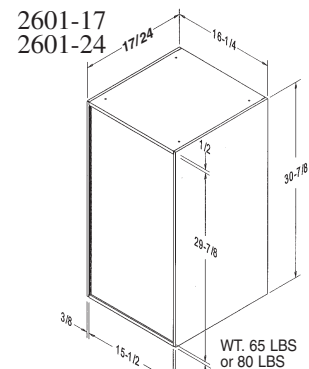

SINGLE WIDTH, (1) MULTI-TASK LOCKER,  
16-1/4" W x 30-7/8" H, 17" D or 24" D

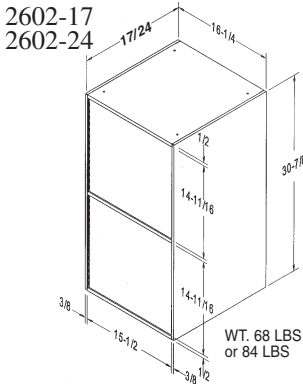

SINGLE WIDTH, (2) MANAGER/CASH LOCKERS  
16-1/4" W x 30-7/8" H x 17" D or 24" D

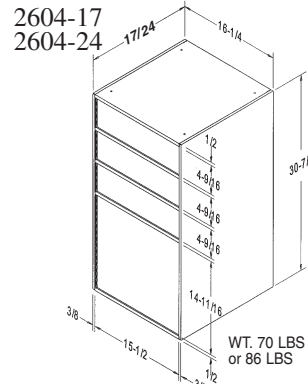

SINGLE WIDTH, (3) TELLER LOCKERS OVER  
(1) MANAGER CASH LOCKER,  
16-1/4" W x 30-7/8" H x 17" D or 24" D

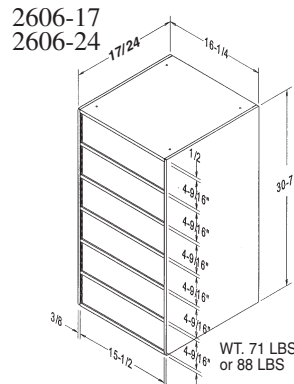

SINGLE WIDTH, (6) TELLER LOCKERS  
16-1/4" W x 30-7/8" H, 17" D or 24" D

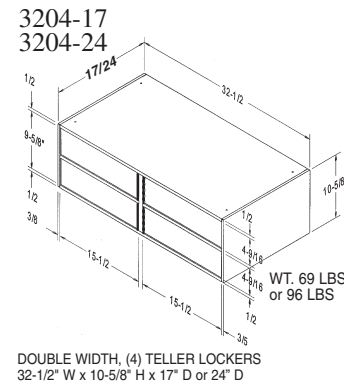

DOUBLE WIDTH, (4) TELLER LOCKERS  
32-1/2" W x 10-5/8" H x 17" D or 24" D

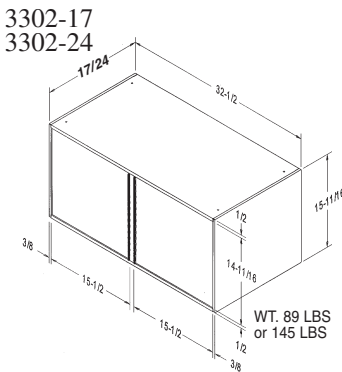

DOUBLE WIDTH, (2) MANAGER/CASH LOCKERS,  
32-1/2" W x 15-11/16" H x 17" D or 24" D

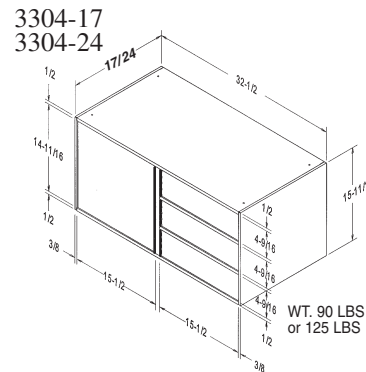

DOUBLE WIDTH, (3) TELLER LOCKERS AND  
(1) MANAGER/CASH LOCKER,  
32-1/2" W x 15-11/16" H x 17" D or 24" D

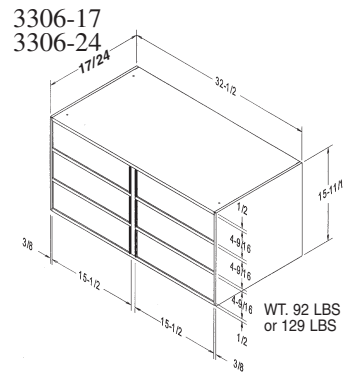

DOUBLE WIDTH, (6) TELLER LOCKERS  
32-1/2" W x 15-11/16" H x 17" D or 24" D

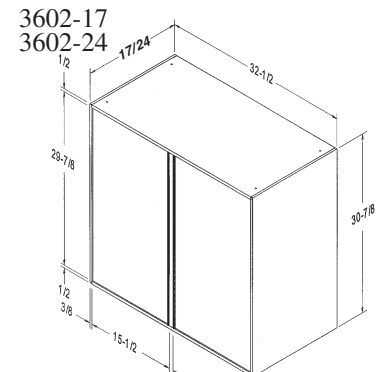

DOUBLE WIDTH, (2) MULTI-TASK LOCKERS,  
32-1/2" W x 30-7/8" H x 17" D  
or 24" D

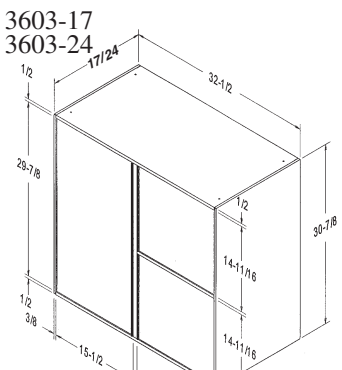

DOUBLE WIDTH, (1) MULTI-TASK  
LOCKER AND (2) MANAGER/CASH LOCKERS,  
32-1/2" W x 30-7/8" H x 17" D or 24" D

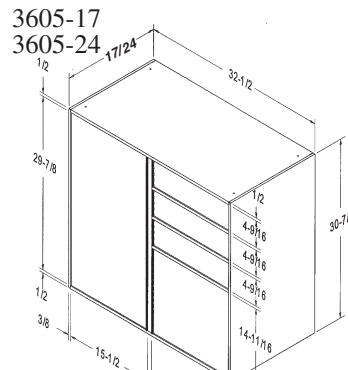

DOUBLE WIDTH, (1) MULTI-TASK LOCKER AND  
(3) TELLER LOCKERS OVER (1) MANAGER/CASH  
LOCKERS, 32-1/2" W x 30-7/8" H x 17" D or 24" D

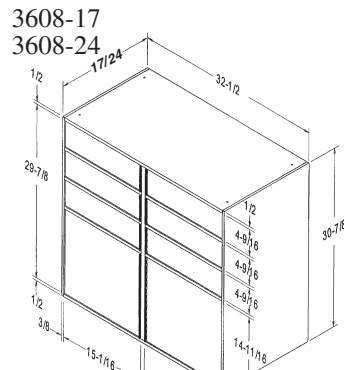

DOUBLE WIDTH, (3) MULTI-TASK LOCKERS OVER  
(1) MANAGER/ CASH LOCKER ON LEFT AND (3) TELLER  
LOCKERS OVER (1) MANAGER/CASH LOCKER ON  
RIGHT, 32-1/2" W x 30-7/8" H x 17" D or 24" D

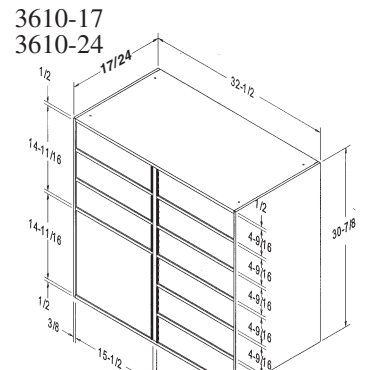

DOUBLE WIDTH, (3) TELLER LOCKERS OVER  
(1) MANAGER/CASH LOCKER ON ONE SIDE AND  
(6) TELLER LOCKERS ON ONE SIDE,  
32-1/2" W x 30-7/8" H x 17" D or 24" D

## **FENCO's** Teller Counters *"If we build it, they will come."*

You may not get Shoeless Joe Jackson at your newly built front counter looking to make a deposit. Moonlight Graham will probably not make your Grand Opening. Unfortunately both Kevin Costner & James Earl Jones will be too busy making their latest movie to visit. However, your Dad may just stop in to take a peek around to see what you did with the place – that's a good thing! We expect you'll be quite proud to share your **FENCO** counter experience from conception to reality with your Dad or anyone.

That truly is how it works; from conception to reality. **FENCO** teller counters are built to suit your needs and vision. We start with ideas and a basic floor plan. We mold those ideas into a layout at your office. That layout soon becomes a **FENCO** produced CAD drawing which your authorized dealer reviews with you to ensure we have your vision intact and the required security in place. He or she will discuss with you the daygates required (counter access), end panels or partition walls to effectively close and secure your counter working area, wiring access, color selections (any current Wilson Art plastic laminate) and all your available options required, to make your vision a reality.

You'll want to think about wood molding accents on your counter & riser fronts, offset color schemes to accent your deal areas, teller window closures, inlaid dealer area acrylics available (Corian), check desks, back counter countertops, drive-up countertops, coupon booth countertops and of course your **FENCO** undercounter steel pedestal layout to fit within. He or she will remind you of the absolute need to receive, acknowledge and sign off on the required field dimensions necessary to ensure a clean fitting installation. Trust us – there is little more frustrating than a counter layout built to 25'6" wide for a building area that offers only a 25' foot opening. Your dream just got nightmarish, so be careful. Think of the time you purchased that beautiful bedroom set and couldn't get it up around the stairs. Not a good thing!

After receipt of your signed drawing for approval we go to work. Expect 30-35 days to produce your project and 24-48 hours to install it. When we're done and you are satisfied, give your Dad a call. Tell him the voice you heard wasn't Shoeless Joe Jackson after all. Rather, it was your **FENCO** salesperson, but you sure would like him to stop down anyway. This is a good thing.

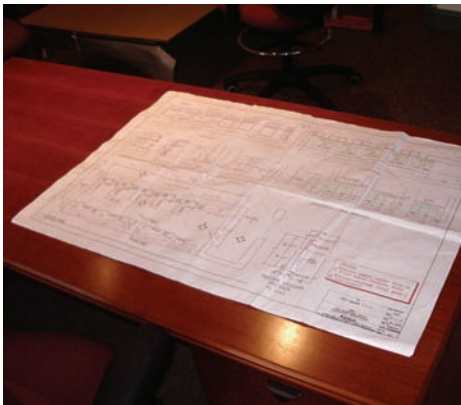

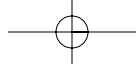

## Fenco Check Desks

Check desks are a vital aspect of your lobby design layout. They too need to not only be aesthetic, but functional to meet your branch flow requirements.

**FENCO** designs & builds your check desk to meet your flow demand. Less flow allows for single user design, medium flow is for a double user design and high flow is for a four-sided user design.

With the knowledge of your expected flow, **FENCO** will provide a design to meet both your customer flow within the design perspective of your teller counter. All check desks, just like our teller counters, are designed and made custom to suit. Below are a few examples to pique your imagination.

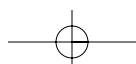

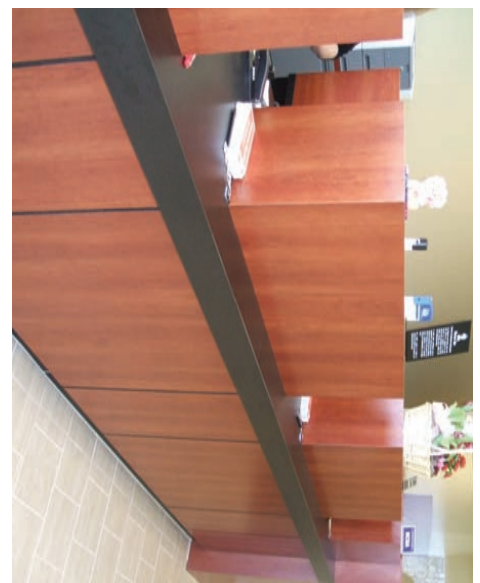
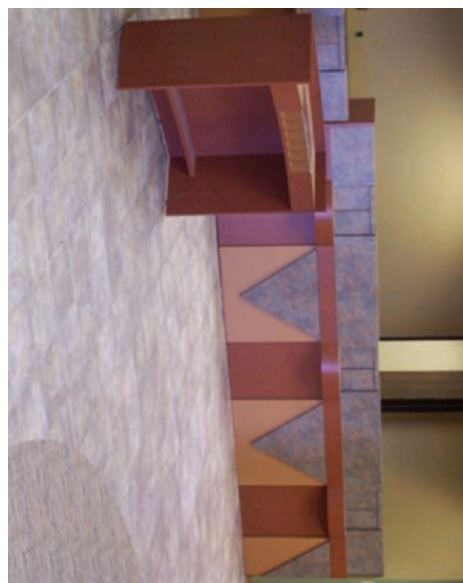
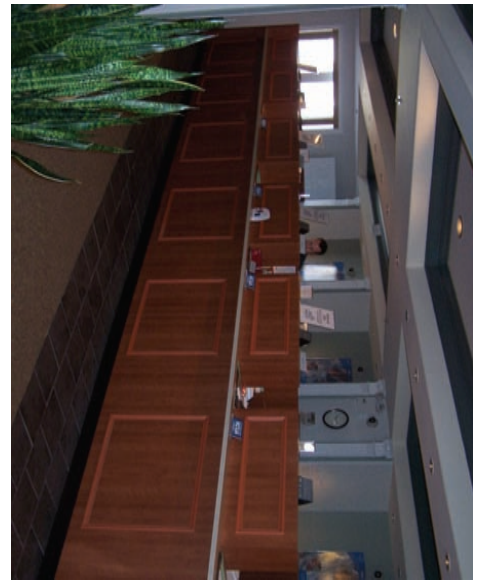
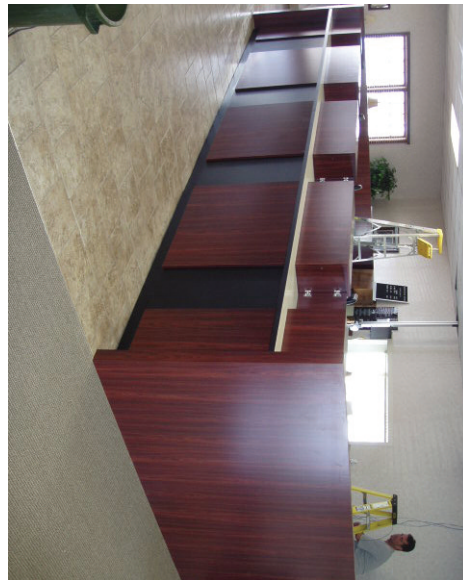

# Fenco

4422 Route 130 South • P.O. Box 1238 • Burlington, NJ USA • 08016-1238  
1-609-387-7580 • 1-800-486-8484 • Fax: 1-609-387-0803 • email: [uh.fenco@verizon.net](mailto:uh.fenco@verizon.net) • [www.fencobankequipment.com](http://www.fencobankequipment.com)